

SECTION **RAX**  
REAR AXLE

A  
B  
C

RAX

CONTENTS

E  
F  
G  
H  
I  
J  
K  
L  
M

<b>PRECAUTIONS</b> .....	<b>2</b>	<b>INSTALLATION</b> .....	<b>6</b>
Caution .....	2	Disassembly and Assembly .....	7
<b>PREPARATION</b> .....	<b>3</b>	DISASSEMBLY .....	7
Special Service Tools (SST) .....	3	INSPECTION AFTER DISASSEMBLY .....	7
Commercial Service Tools .....	3	ASSEMBLY .....	8
<b>NOISE, VIBRATION AND HARSHNESS (NVH)</b>		INSPECTION AFTER ASSEMBLY .....	8
<b>TROUBLESHOOTING</b> .....	<b>4</b>	<b>REAR DRIVE SHAFT</b> .....	<b>9</b>
NVH Troubleshooting Chart .....	4	Removal and Installation .....	9
<b>REAR WHEEL HUB AND KNUCKLE</b> .....	<b>5</b>	COMPONENTS .....	9
On-Vehicle Inspection .....	5	REMOVAL .....	9
WHEEL BEARING INSPECTION .....	5	INSPECTION AFTER REMOVAL .....	9
Removal and Installation .....	5	INSTALLATION .....	9
COMPONENTS .....	5	Disassembly and Assembly .....	10
REMOVAL .....	5	COMPONENTS .....	10
INSPECTION AFTER REMOVAL .....	6	DISASSEMBLY .....	10
		INSPECTION AFTER DISASSEMBLY .....	11
		ASSEMBLY .....	12
		<b>SERVICE DATA AND SPECIFICATIONS (SDS)</b> .....	<b>15</b>
		Wheel Bearing .....	15
		Drive Shaft .....	15

# PRECAUTIONS

---

## PRECAUTIONS

PFP:00001

### Caution

NDS000CD

Observe the following precautions when disassembling and servicing drive shaft.

- Perform work in a location which is as dust-free as possible.
- Before disassembling and servicing, clean the outside of parts.
- Prevention of the entry of foreign objects must be taken into account during disassembly of the service location.
- Disassembled parts must be carefully reassembled in the correct order. If work is interrupted, a clean cover must be placed over parts.
- Paper shop cloths must be used. Fabric shop cloths must not be used because of the danger of lint adhering to parts.
- Disassembled parts (except for rubber parts) should be cleaned with kerosene which shall be removed by blowing with air or wiping with paper shop cloths.

# PREPARATION

## PREPARATION

PFP:00002

### Special Service Tools (SST)

NDS000CE

The actual shapes of Kent-Moore tools may differ from those of special service tools illustrated here.

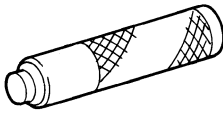
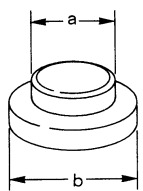
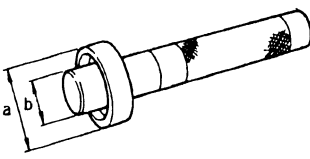
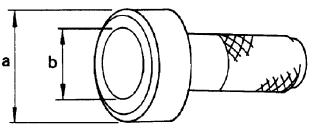
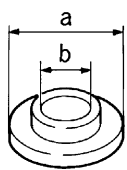
Tool number (Kent-Moore No.) Tool name	Description
ST33251000 ( — ) Drift  <p style="text-align: right; margin-right: 50px;">ZZA0982D</p>	<ul style="list-style-type: none"> <li>● Removing wheel hub</li> <li>● Removing wheel bearing outer side inner race</li> <li>● Installing wheel hub</li> <li>● Inspection of wheel bearing rotating torque</li> </ul>
ST35300000 ( — ) Drift a: 45 mm (1.77 in) dia. b: 59 mm (2.32 in) dia.  <p style="text-align: right; margin-right: 50px;">ZZA0881D</p>	<ul style="list-style-type: none"> <li>● Installing wheel hub</li> <li>● Inspection of wheel bearing rotating torque</li> </ul>
KV40100900 ( — ) Drift a: 52 mm (2.05 in) dia. b: —  <p style="text-align: right; margin-right: 50px;">ZZA0539D</p>	Wheel bearing rotating torque inspection
KV38100500 ( — ) Drift a: 80 mm (3.15 in) dia. b: 60 mm (2.36 in) dia.  <p style="text-align: right; margin-right: 50px;">ZZA0701D</p>	Installing drive shaft plug
KV38102200 ( — ) Drift a: 90 mm (3.54 in) dia. b: 31 mm (1.22 in) dia.  <p style="text-align: right; margin-right: 50px;">ZZA0920D</p>	Installing drive shaft plug

A  
B  
C  
**RAX**  
E  
F  
G  
H  
I  
J  
K  
L  
M

### Commercial Service Tools

NDS000CF

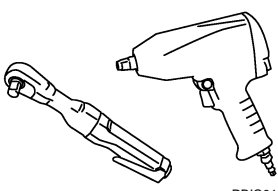
Tool name	Description
Power tool  <p style="text-align: right; margin-right: 50px;">PBIC0190E</p>	<ul style="list-style-type: none"> <li>● Removing wheel nuts</li> <li>● Removing brake caliper assembly</li> <li>● Removing wheel hub and bearing assembly</li> <li>● Removing suspension links</li> <li>● Removing drive shaft fixing bolts and nuts</li> </ul>

# NOISE, VIBRATION AND HARSHNESS (NVH) TROUBLESHOOTING

## NOISE, VIBRATION AND HARSHNESS (NVH) TROUBLESHOOTING

PF0:00003

### NVH Troubleshooting Chart

NDS000CG

Use chart below to help you find the cause of the symptom. If necessary, repair or replace these parts.

Reference page			—	RAX-9	—	RAX-5	—	NVH in PR section	NVH in RFD section	NVH in RAX and RSU section	Refer to REAR AXLE in this chart.	NVH in WT section	NVH in WT section	Refer to DRIVE SHAFT in this chart.	NVH in BR section	NVH in PS section	
Possible cause and SUSPECTED PARTS			Excessive joint angle	Joint sliding resistance	Imbalance	Improper installation, looseness	Parts interference	PROPELLER SHAFT	DIFFERENTIAL	REAR AXLE AND REAR SUSPENSION	REAR AXLE	TIRES	ROAD WHEEL	DRIVE SHAFT	BRAKES	STEERING	
Symptom	DRIVE SHAFT	Noise	x	x				x	x	x	x	x	x		x	x	
		Shake	x		x			x		x	x	x	x		x	x	
	REAR AXLE	Noise				x	x	x	x	x		x	x	x	x	x	x
		Shake				x	x	x		x		x	x	x	x	x	x
		Vibration				x	x	x		x		x		x			x
		Shimmy				x	x			x		x	x			x	x
		Judder				x				x		x	x			x	x
		Poor quality ride or handling				x	x			x		x	x				

x: Applicable

# REAR WHEEL HUB AND KNUCKLE

## REAR WHEEL HUB AND KNUCKLE

PFP:40202

### On-Vehicle Inspection

NDS000D1

Make sure the mounting conditions (looseness, back lash) of each component and component status (wear, damage) are normal.

### WHEEL BEARING INSPECTION

With the vehicle raised, inspect the following.

- Move wheel hub in the axial direction by hand. Check that there is no looseness of front wheel bearing.

**Axial end play : 0.05 mm (0.002 in) or less**

- Rotate wheel hub and make sure there is no unusual noise or other irregular conditions. If there are any irregular conditions, replace wheel hub and bearing assembly.

### Removal and Installation COMPONENTS

NDS000C1

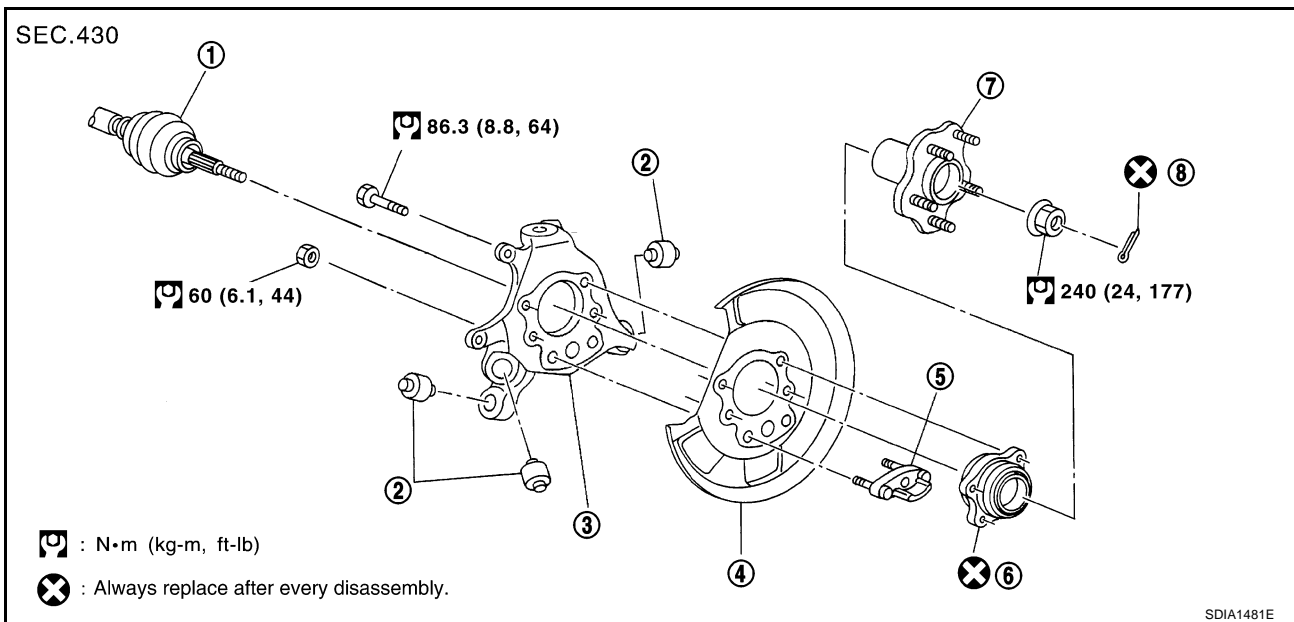

- |                |                 |                  |
|----------------|-----------------|------------------|
| 1. Drive shaft | 2. Bushing      | 3. Axle          |
| 4. Back plate  | 5. Anchor block | 6. Wheel bearing |
| 7. Wheel hub   | 8. Cotter pin   |                  |

### REMOVAL

1. Remove tires from vehicle with power tool.
2. Remove cotter pin. Then remove lock nut from drive shaft.
3. Remove brake caliper with power tool. Hang it in a place where it will not interfere with work. Refer to [BR-27, "Removal and Installation of Brake Caliper Assembly"](#).

#### NOTE:

- Avoid depressing brake pedal while brake caliper is removed.

4. Remove disc rotor. Refer to [BR-27, "Removal and Installation of Brake Caliper Assembly"](#).
5. Remove parking cable and parking shoe from back plate. Refer to [PB-4, "Removal and Installation"](#).
6. Remove wheel sensor from axle. Refer to [BRC-55, "WHEEL SENSORS"](#).

#### CAUTION:

**Do not pull on wheel sensor harness.**

7. Separate drive shaft from wheel hub and bearing assembly by lightly tapping the end with a suitable hammer and wood block. If it is hard to separate, use a suitable puller.
8. Remove fixing bolts of wheel hub and bearing assembly with power tool, then remove wheel hub and bearing assembly from axle.

# REAR WHEEL HUB AND KNUCKLE

9. Remove parking brake cable and parking brake shoe from back plate. Refer to [PB-6, "PARKING BRAKE SHOE"](#) and [PB-4, "PARKING BRAKE CONTROL"](#).
10. Remove fixing nuts of anchor block with power tool, then remove anchor block and back plate from axle.
11. Loosen fixing bolts and nuts of front lower link, radius rod, and rear lower link in side of suspension member.
12. Set jack under rear lower link. Then remove fixing bolt in front lower link side of shock absorber with power tool.
13. Remove bolt and nut in axle side of rear lower link with power tool. Then remove coil spring. Refer to [RSU-15, "REAR LOWER LINK & COIL SPRING"](#).
14. Remove fixing bolts and nuts in axle side of front lower link, radius rod with power tool.
15. Remove suspension arm and cotter pin at axle, then loosen mounting nut.
16. Use a ball joint remover (suitable tool) to remove suspension arm from axle. Be careful not to damage ball joint boot.

**CAUTION:**

**Tighten temporarily mounting nut to prevent damage to threads and to prevent ball joint remover (suitable tool) from coming off.**

17. Remove axle from vehicle.

## INSPECTION AFTER REMOVAL

Check for deformity, cracks and damage on each parts, replace if necessary.

### Ball Joint Inspection

Check for boot breakage, axial looseness, and torque of suspension arm ball joint. Refer to [RSU-11, "INSPECTION AFTER REMOVAL"](#).

## INSTALLATION

- Refer to [RAX-5, "Removal and Installation"](#) for tightening torque. Install in the reverse order of removal.  
**NOTE:**  
Refer to component parts location and do not reuse non-reusable parts.
- Perform final tightening of installation position of suspension links (rubber bushing) under unladen conditions with tires on level ground, Check wheel alignment. Refer to [RSU-5, "Wheel Alignment Inspection"](#).
- After adjusting wheel alignment, adjust neutral position of steering angle sensor. Refer to [BRC-6, "Adjustment of Steering Angle Sensor Neutral Position"](#).

# REAR WHEEL HUB AND KNUCKLE

NDS000CJ

## Disassembly and Assembly

### DISASSEMBLY

#### Wheel Bearing

#### CAUTION:

Do not disassemble if wheel bearing has no trouble.

1. Remove wheel bearing fixing bolts and anchor block fixing nuts, and remove wheel hub and bearing assembly, back plate and anchor block from axle.
2. Using a drift (SST) and a puller (suitable tool), press wheel hub out to remove from wheel bearing.

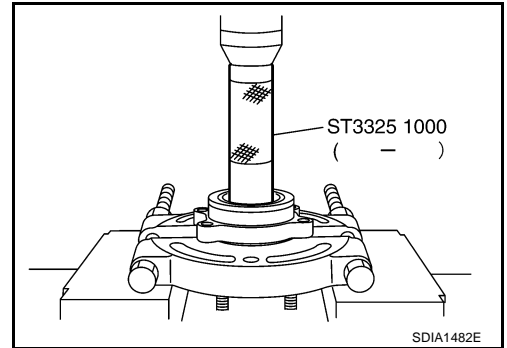

3. Using a drift (SST) and a puller (suitable tool), press wheel bearing outer side inner race out to remove from wheel hub.

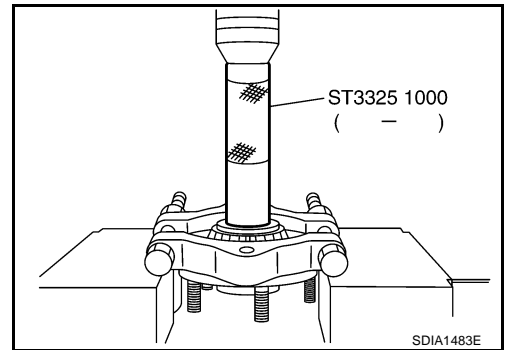

#### Bushing

Using a suitable drift, remove each bushing from axle.

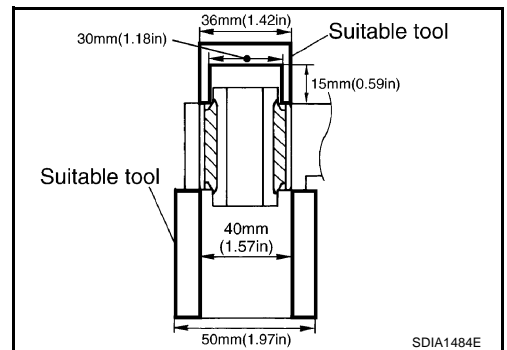

### INSPECTION AFTER DISASSEMBLY

Check for deformity, cracks and damage of each parts, replace if necessary.

#### Wheel Hub

Inspect wheel hub for deformation, cracks, and other damage. If any irregular conditions are found, replace wheel hub.

#### Axle

Inspect axle for deformation, cracks, and other damage. If any irregular conditions are found, replace axle.

#### Back Plate

Inspect back plate for deformation, cracks, and other damage. If any irregular conditions are found, replace back plate.

A  
B  
C  
RAX  
E  
F  
G  
H  
I  
J  
K  
L  
M

# REAR WHEEL HUB AND KNUCKLE

## ASSEMBLY

### Bushing

Using a suitable drift to install each bushing onto axle.

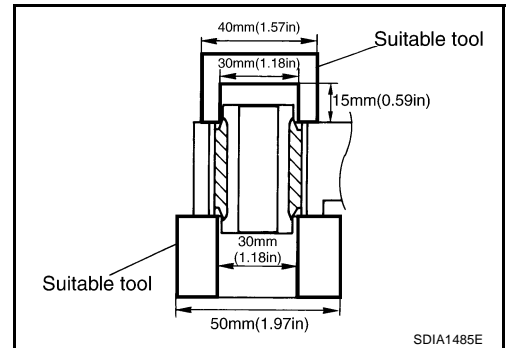

### Wheel Bearing

1. Press fit a wheel hub into wheel bearing with a drift (SST).

#### CAUTION:

- Press fit a drift (SST) while holding it against wheel bearing inner side inner race.
- Wheel bearing cannot be reused. Do not attempt to reuse it.

#### NOTE:

Final press load guideline 49,033 N (5,000 kg, 11,000 lb)

2. Install back plate and wheel hub and bearing assembly.
3. Install anchor block onto axle.

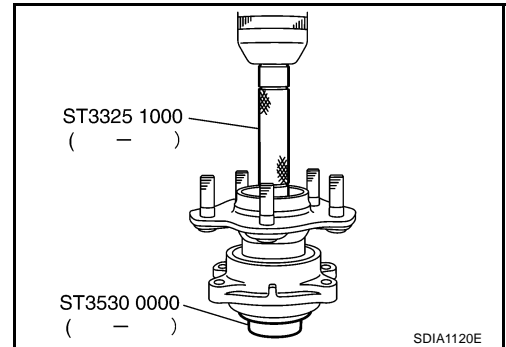

### INSPECTION AFTER ASSEMBLY

1. With wheel bearing pressed into axle housing, apply 49,033 N (5,000 kg, 11,000 lb) to wheel hub and rotate both clockwise and counterclockwise 10 times to minimize resistance.
2. Attach spring scale in the position shown in illustration and pull at a rate of  $10 \pm 2$  rpm to measure rotating torque.

#### Rotating torque:

Less than 2.7 N-m (0.28 kg-m, 24 in-lb)

#### Spring scale reading:

Less than 26.6 N (2.7 kg, 5.95 lb)

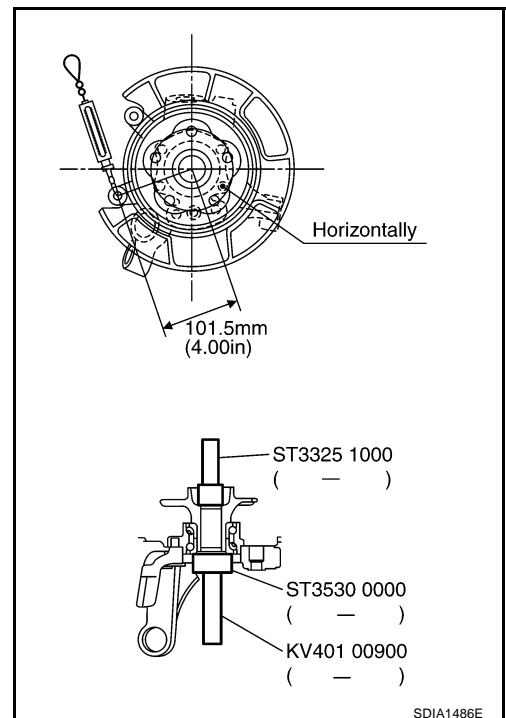



# REAR DRIVE SHAFT

## REAR DRIVE SHAFT

PFP:39600

### Removal and Installation COMPONENTS

NDS000CK

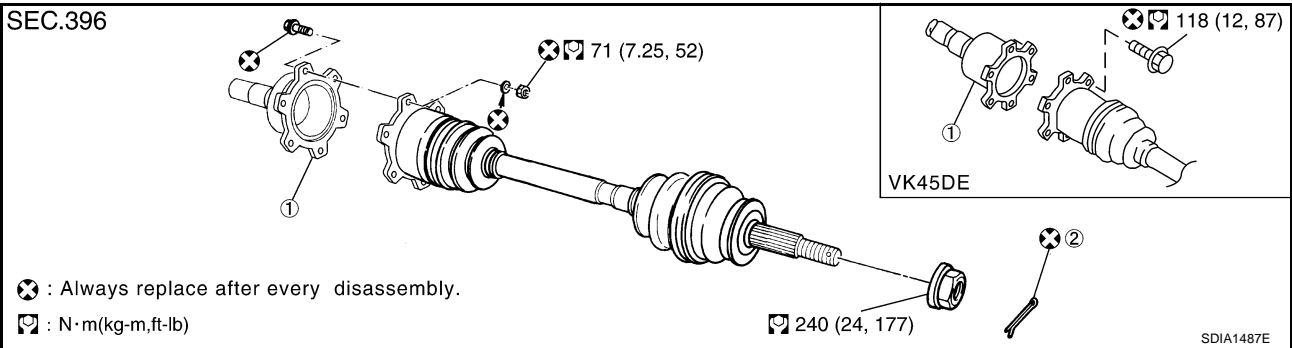

1. Side flange

2. Cotter pin

### REMOVAL

1. Remove tires from vehicle with power tool.
2. Remove cotter pin. Then remove lock nut from drive shaft.
3. Remove fixing nuts and bolts between side flange and drive shaft with power tool.
4. Using a puller (suitable tool), remove drive shaft from steering knuckle.

#### CAUTION:

**When removing drive shaft, do not apply an excessive angle to drive shaft joint. Also be careful not to excessively extend slide joint.**

5. Remove drive shaft from axle.

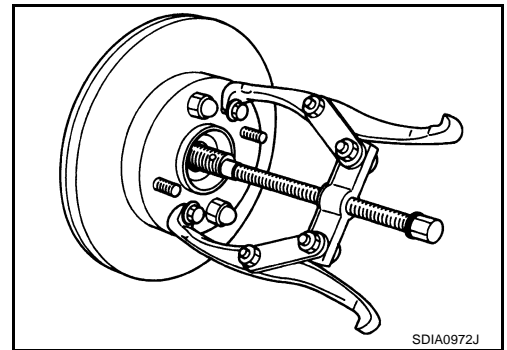

### INSPECTION AFTER REMOVAL

- Move joint up/down, left/right, and in the axial direction. Check for any rough movement or significant looseness.
- Check boot for cracks or other damage, and also for grease leakage.
- If a trouble is found, disassemble drive shaft, and then replace with new one.

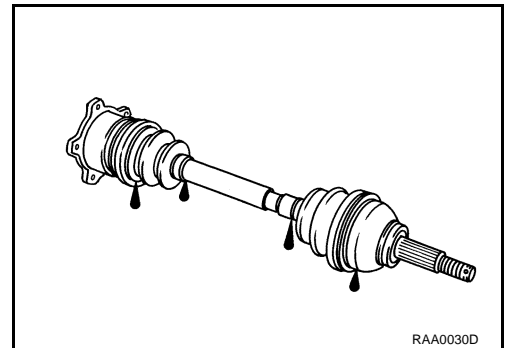

### INSTALLATION

Refer to [RAX-9, "Removal and Installation"](#) for tightening torque. Install in the reverse order of removal.

#### NOTE:

Refer to component parts location and do not reuse non-reusable parts.

A  
B  
C  
RAX  
E  
F  
G  
H  
I  
J  
K  
L  
M

# REAR DRIVE SHAFT

NDS000CL

## Disassembly and Assembly COMPONENTS

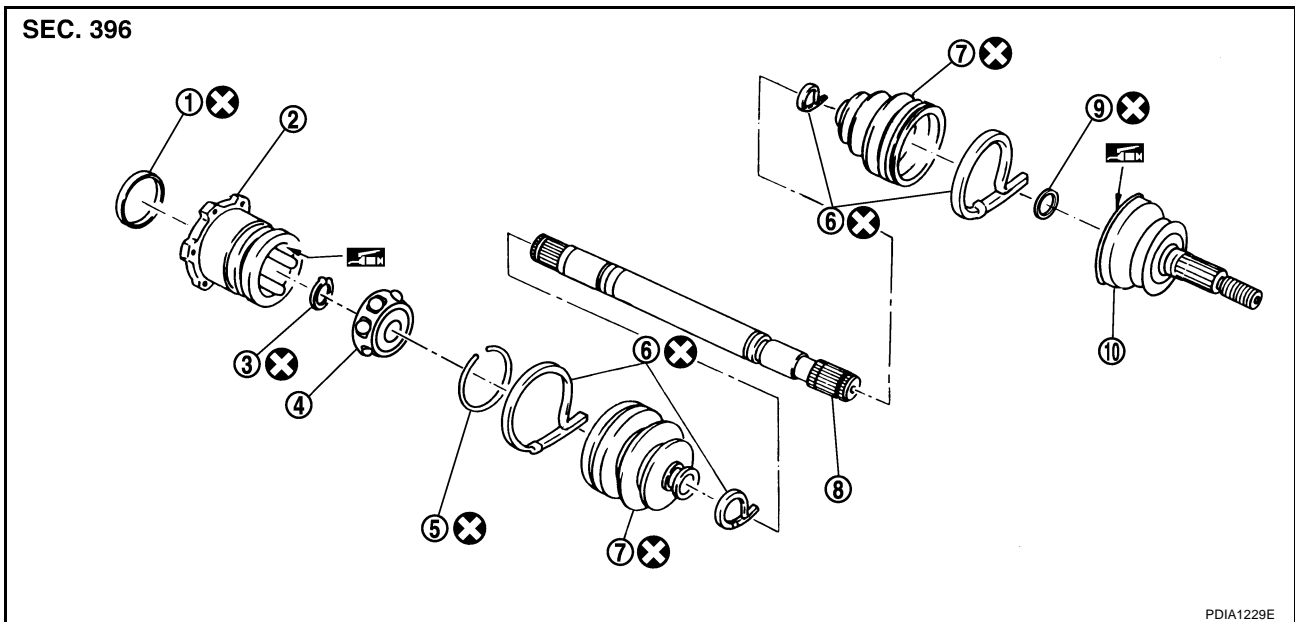

- |   |                 |                  |
|---|-----------------|------------------|
| 1. Plug                                     | 2. Housing      | 3. Snap ring     |
| 4. Ball cage/Steel ball/Inner race assembly | 5. Stopper ring | 6. Boot band     |
| 7. Boot                                     | 8. Shaft        | 9. Circular clip |
| 10. Joint sub-assembly                      |                 |                  |

Refer to [GI-11. "Components"](#) , for the symbols in the figure.

 : Apply Nissan genuine grease or equivalent.

## DISASSEMBLY

### Final Drive Side

1. Press shaft in a vice.

#### **CAUTION:**

**When retaining drive shaft in a vise, always use copper or aluminum plates between vise and shaft.**

2. Remove boot bands.
3. If plug needs to be removed, move boot to wheel side, and drive it out with a plastic hammer.
4. Remove stopper ring with a flat-bladed screwdriver, and pull out housing.

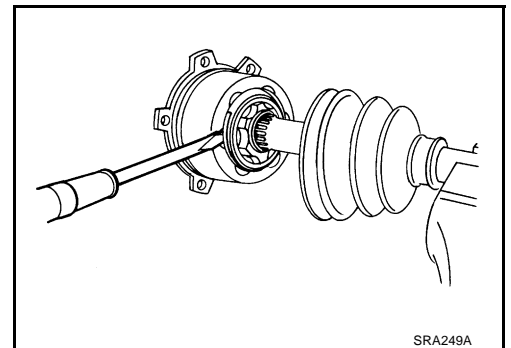

# REAR DRIVE SHAFT

5. Remove snap ring, then remove ball cage/steel ball/inner race assembly from shaft.
6. Remove boot from shaft.
7. Remove old grease on housing with paper towels.

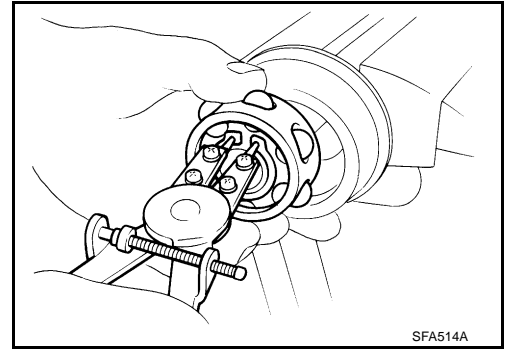

A  
B  
C

RAX

## Wheel Side

1. Place shaft in a vise.

### CAUTION:

**When retaining drive shaft in a vise, always use copper or aluminum plates between vise and shaft.**

2. Remove boot bands. Then remove boot from joint sub-assembly.
3. Screw a drive shaft puller 30 mm (1.18 in) or more into threaded part of joint sub-assembly. Pull joint sub-assembly out of shaft.

### CAUTION:

- If joint sub-assembly cannot be removed after five or more unsuccessful attempts, replace shaft and joint sub-assembly as a set.
- Align sliding hammer and drive shaft and remove them by pulling directly.

4. Remove boot from shaft.
5. Remove circular clip from shaft.
6. While rotating ball cage, remove old grease on joint sub-assembly with paper towels.

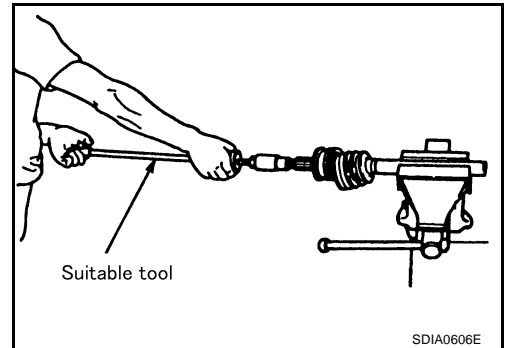

E  
F  
G

H

I

J

## INSPECTION AFTER DISASSEMBLY

### Shaft

Replace shaft if there is any runout, cracking, or other damage.

### Joint Sub-Assembly

- Make sure there is no rough rotation or unusual axial looseness.
- Make sure there is no foreign material inside joint.
- Check joint sub-assembly for compression scars, cracks, or fractures.

### CAUTION:

**If there are any irregular conditions of joint sub-assembly components, replace the entire joint sub-assembly.**

K

L

M

### Sliding Joint Side (Housing)

- Make sure there are no compression scars, cracks, fractures or unusual wear of ball rolling surface.
- Make sure there is no damage to shaft screws.
- Make sure there is no deformation of boot installation parts.

### Ball Cage

Make sure there are no compression scars, cracks, fractures of sliding surface.

### Steel Ball

Make sure there are no compression scars, cracks, fractures or unusual wear.

### Inner Race

- Check ball sliding surface for compression scars, cracks, or fractures.
- Make sure there is no damage to serrated part.

# REAR DRIVE SHAFT

## CAUTION:

If there are any irregular conditions in the component, replace with a new set of housing, ball cage, steel ball and inner race.

## ASSEMBLY

### Final Drive Side

1. If plug has been removed, use a drift (SST) to press in a new one.

#### NOTE:

Discard old plug; replace with new one.

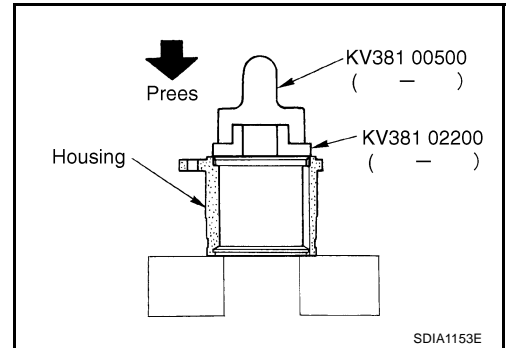

2. Wind serrated part of shaft with tape. Install boot band and boot to shaft. Be careful not to damage boot.

#### NOTE:

Discard old boot band and boot; replace with each new one.

3. Remove protective tape wound around serrated part of shaft.

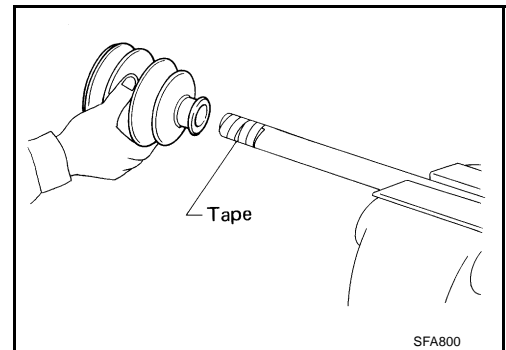

4. Install ball cage/steel ball/inner race assembly to shaft, and secure them tightly with a snap ring.

#### NOTE:

Discard old snap ring; replace with new one.

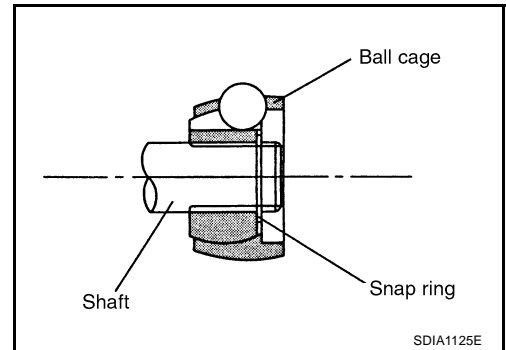

5. Insert the amount of grease (NISSAN genuine grease or equivalent) onto housing (\* point) to the quantity mentioned below, and install it to shaft.

#### Grease amount

**VK45DE : 175 – 195 g (6.17 – 6.88 oz)**

**VQ35DE : 124 – 134 g (4.37 – 4.73 oz)**

6. Install stopper ring to housing.
7. After installed, pull shaft to check engagement between joint sub-assembly and stopper ring.

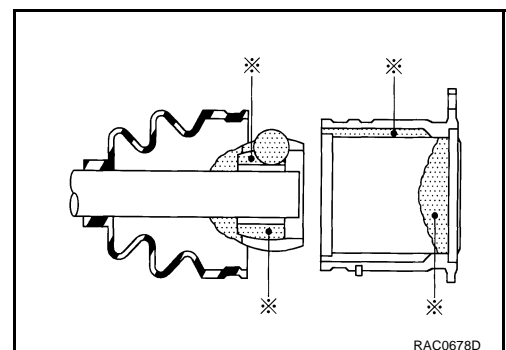

## REAR DRIVE SHAFT

- Install boot securely into grooves (indicated by \* marks) shown in the figure.

**CAUTION:**

**If there is grease on boot mounting surfaces (indicated by \* marks) of shaft and housing, boot may come off. Remove all grease from surfaces.**

- Make sure boot installation length "L" is the length indicated below. Insert a flat-bladed screwdriver or similar tool into smaller side of boot. Bleed air from boot to prevent boot deformation.

**Boot installation Length "L"**

**VK45DE : 147.9 mm (5.82 in)**

**VQ35DE : 93.9 mm (3.697 in)**

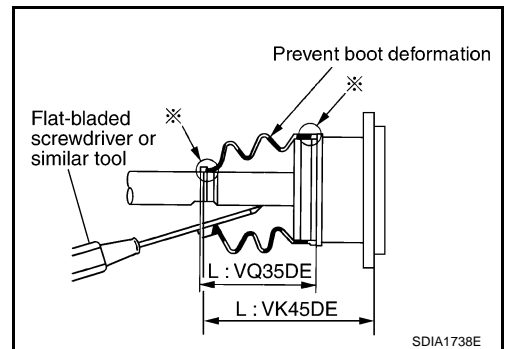

**CAUTION:**

- **Boot may break if boot installation length is less than standard value.**
- **Take care not to touch the tip of screwdriver to inside of boot.**

- Secure big and small ends of boot with new boot bands as shown in the figure.

**NOTE:**

Discard old boot bands; replace with new ones.

- After installing housing and shaft, rotate boot to check whether or not the actual position is correct. If boot position is not correct, secure boot with new boot band again.

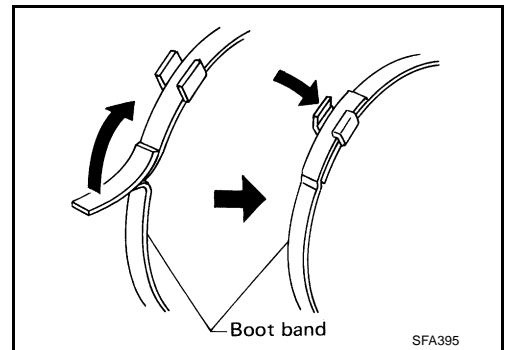

### Wheel Side

- Insert the amount of grease (NISSAN genuine grease or equivalent) into joint sub-assembly serration hole until grease begins to ooze from ball groove and serration hole. After insert grease, use a shop cloth to wipe off old grease that has oozed out.

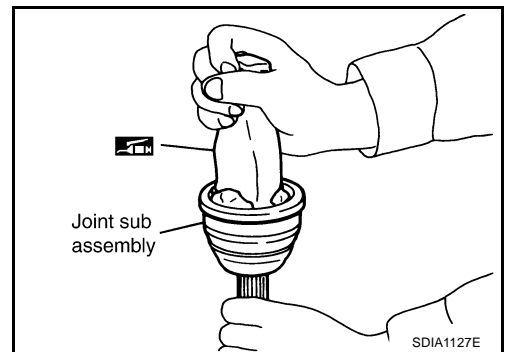

- Wind serrated part of shaft with tape. Install boot band and boot to shaft. Be careful not to damage boot.

**NOTE:**

Discard old boot band and boot; replace with each new one.

- Remove protective tape wound around serrated part of shaft.

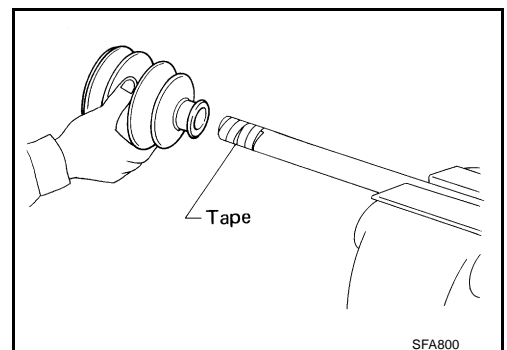

## REAR DRIVE SHAFT

- Attach circular clip to shaft. At this time, circular clip must fit securely into shaft groove. Attach nut to joint sub-assembly. Use a wooden hammer to press-fit.

**NOTE:**

Discard old circular clip; replace with new one.

- Insert the amount of grease (NISSAN genuine grease or equivalent) listed below into housing from large end of boot.

**Grease amount**

**VK45DE : 140 – 160 g (4.93 – 5.64 oz)**

**VQ35DE : 86 – 96 g (3.03 – 3.39 oz)**

- Install boot securely into grooves (indicated by \* marks) shown in the figure.

**CAUTION:**

**If there is grease on boot mounting surfaces (indicated by \* marks) of shaft and housing, boot may come off. Remove all grease from surfaces.**

- Make sure boot installation length “L” is the length indicated below. Insert a flat-bladed screwdriver or similar tool into smaller side of boot. Bleed air from boot to prevent boot deformation.

**Boot installation length “L”**

**VK45DE : 141.5 mm (5.57 in)**

**VQ35DE : 97 mm (3.82 in)**

**CAUTION:**

- **Boot may break if boot installation length is less than standard value.**
- **Be careful that screwdriver tip does not contact inside surface of boot.**

- Secure big and small ends of boot with new boot bands as shown in the figure.

**NOTE:**

Discard old boot bands; replace with new ones.

- After installing joint sub-assembly and shaft, rotate boot to check whether or not the actual position is correct. If boot position is not correct, secure boot with new boot bands again.

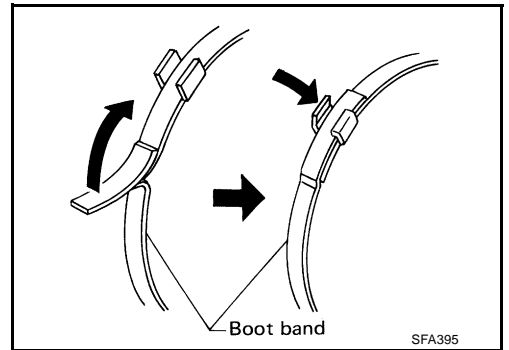
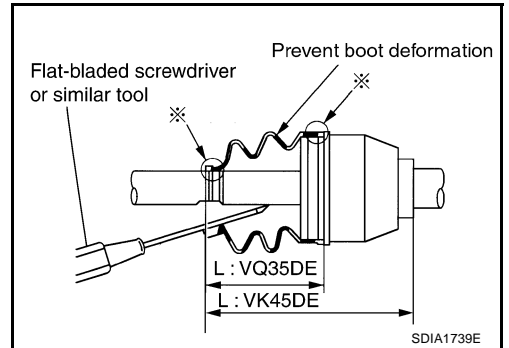
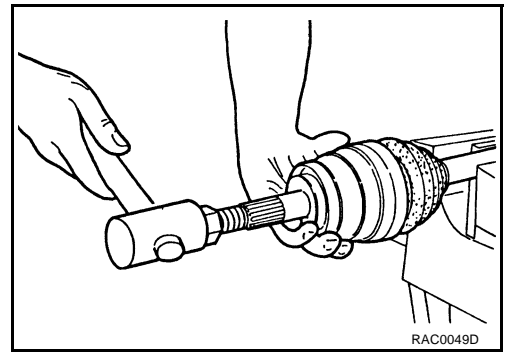

# SERVICE DATA AND SPECIFICATIONS (SDS)

## SERVICE DATA AND SPECIFICATIONS (SDS)

PFP:00030

### Wheel Bearing

NDS000CM

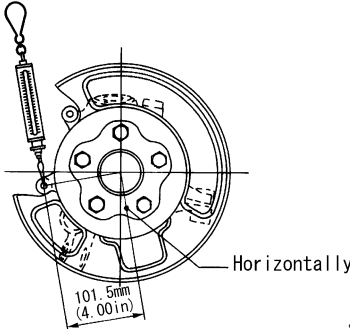
Axial end play	0.05 mm (0.002 in) or less
Rotational torque	At a load of 49,033 N (5,000 kg, 11,000 lb) Less than 2.7 N·m (0.28 kg-m, 24 in-lb)
Measurement of spring scale	Less than 26.6 N (2.7 kg, 5.95 lb)
Measuring point (Brake caliper installation points)	 <p style="text-align: right;">SDIA0801E</p>

### Drive Shaft

NDS000CN

Joint	Wheel side		Final drive side	
	VQ35DE	VK45DE	VQ35DE	VK45DE
Grease quantity	86 – 96 g (3.03 – 3.39 oz)	140 – 160 g (4.93 – 5.64 oz)	124 – 134 g (4.37 – 4.73 oz)	175 – 195 g (6.17 – 6.88 oz)
Boots installed length	97 mm (3.82 in)	141.5 mm (5.57 in)	93.9 mm (3.697 in)	147.9 mm (5.82 in)

# SERVICE DATA AND SPECIFICATIONS (SDS)

---